



ST. ANNE'S

COLLEGE OF ENGINEERING AND TECHNOLOGY

(Approved by AICTE, New Delhi. Affiliated to Anna University, Chennai)

(An ISO 9001: 2015 Certified Institution)

ANGUCHETTYPALAYAM, PANRUTI – 607 106.

QUESTION BANK

PERIOD: JAN 2021 - MAY 2021

BATCH: 2018 – 2022

BRANCH: ECE

YEAR/SEM: III/VI

SUB CODE/NAME: EC8002 - MULTIMEDIA COMPRESSION AND COMMUNICATION

UNIT I - AUDIO COMPRESSION

PART – A

1. Name the three features that determine the perception of the ear? [D] [Apr/May-2019]

Pitch: This is closely related to the frequency of the signal. This is important since ear is more sensitive to signals in the range 2-5kHz

Period: This is the duration of the signal

Loudness: This is determined by the amount of energy in the signal

2. Define delta Modulation?

Delta modulation provides a staircase approximation of the input sampled signal where only one bit per sample is transmitted. This one bit is sent by comparing the present sample value with the previous sample value and the result whether the amplitude is to be increased or decreased is transmitted. If the step is reduced, 0 is transmitted and if the step is increased then 1 is transmitted.

3. How can a pitch be defined? [D] [Apr/May-2018]

Pitch is closely related to the frequency of the signal. This is important since ear is more sensitive to signals in the range 2-5kHz.

4. What are the types of noise in delta modulation?

- ✓ Slope Over load distortion (when Δ is small)
- ✓ Granular noise (when Δ is large)

5. What are the different delays suffered by CELP coders? [D] [Nov/Dec-2016] [Apr/May-2015]

- ✓ Processing delay
- ✓ Algorithmic delay

6. What are the advantages of adaptive predictive coding? [D] [Nov/Dec-2016] [Apr/May-2015]

- ✓ Even higher levels of compression possible at higher levels of complexity
- ✓ The optimum set of coefficients are then computed and these are used to predict more accurately the previous signal
- ✓ This compression reduce the bandwidth requirements to 8kbps while still obtaining an acceptable perceived quality

7. Give the principle of DPCM. [D] [Nov/Dec-2014]

- ✓ Differential pulse code modulation is a derivative of the standard PCM
- ✓ It uses the fact that the range of differences in amplitudes between successive samples of the audio waveform is less than the range of the actual sample amplitudes
- ✓ Hence fewer bits are required to represent the difference signals than in case of PCM for the same sampling rate. It reduces the bit rate requirements from 64kbps to 56kbps.

8. *If the sampling frequency is 1.5 times the true frequency then what is the alias frequency?* [ID][May/Jun-2016]

$$f_{\text{alias}} = f_{\text{sampling}} - f_{\text{true}}$$

$$f_{\text{sampling}} = 1.5 \times f_{\text{true}}$$

$$f_{\text{alias}} = 1.5 f_{\text{true}} - f_{\text{true}}$$

$$f_{\text{alias}} = 0.5 f_{\text{true}}$$

f_{alias} = alias frequency

f_{sampling} = Sampling frequency

f_{true} = True frequency

9. *Write down the basic principle of vector quantization technique.* [D] [May/Jun-2016]

Vector quantization (VQ) is a classical quantization technique from signal processing that allows the modeling of probability density functions by the distribution of prototype vectors. It was originally used for data compression. It works by dividing a large set of points (vectors) into groups having approximately the same number of points closest to them.

10. *Diagram of differential pulse code modulation encoder and decoder.* [D] [Nov/Dec-2017]

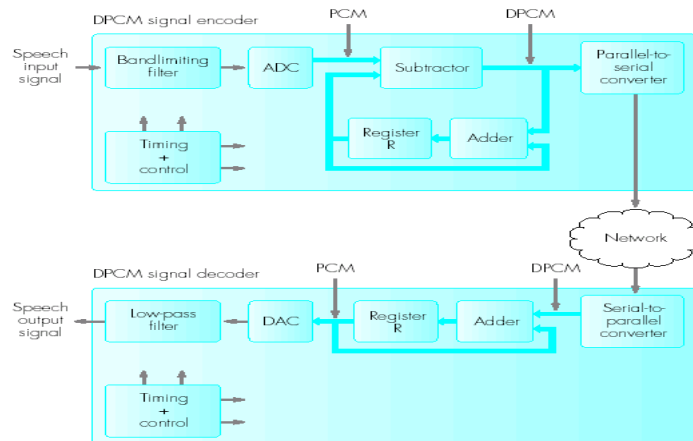

11. *Define Pulse code modulation.* [D]

PCM is essentially analog to digital conversion of a signal type where the information contained in the instantaneous samples of an analog signal is represented by digital words in a serial bit stream

12. *Write the principle of code excited LPC?* [D]

For a limited set of speech segments, features are computed and stored as templates in a Template Code Book. This code book is available both on the encoder and the decoder. The samples in a template are differentially encoded. Each code word transmitted from sending side will select a template that matches best in the codebook available in the decoder side and the speech is reconstructed from this template.

13. *What do you understand from adaptive coding?*

In adaptive coding quantization step size and prediction filter co-efficient are changed as per properties of input signals. This quantization error and number of bits used to represent the sample value. Adaptive coding is used at low bit rates.

14. *What is Linear Predictive Coding?* [D]

Linear predictive coding is a tool used mostly in audio signal processing and speech processing for representing the spectral envelope of a digital signal of speech in compressed form, using the information of a linear predictive model.

15. What is Code Excited LPC? [D]

Code Excited Linear Predictive Coding is a speech coding algorithm. CELP coders use codebook excitation, a long term pitch prediction filter, and a short term formant prediction filter.

16. List out some of the audio compression standards? [D]

- ✓ **G.721:** This standard uses DPCM with eight-order predictor with a bandwidth of 3.4 kHz. The difference values are encoded with either 6 bits (32 kbps) or 5 bits (16 kbps).
- ✓ **G.722:** Uses DPCM and extends bandwidth to 7 kHz using sub band coding. Lower sub band uses 8 kbps sampling rate and higher sub band uses 16 kbps.

17. List the types vocal tract excitation parameters [D]

- ✓ **voiced sound**-This are the sound generated through vocal chords
- ✓ **unvoiced sound**- This are the sound generated through vocal chords are open

18. Define template codebook? [D]

A pre-computed set of templates are held by the encoder and decoder is known as a template codebook

19. What are the two limitations of delta modulation?[D]

1. Slope of overload distortion
2. Granular noise

20. List out the CELP-based standard? [D]

- ✓ G728
- ✓ G729
- ✓ G729A
- ✓ G723.1

21. Define segment? [D]

A block of digitized samples is known as segment

22. Define wave template? [D]

In CELPC model instead of treating each digitized segment independently for encoding purposes, just a limited set of segments are used, each known as a wave template

23. Define Quantization? [D]

Quantization is a process of approximation or rounding off. Assigning PCM codes to absolute magnitudes is called quantization.

24. Define processing and algorithmic delay? [D]

- ✓ The block of digitized samples is analysed by the encoder and the speech is reconstructed at the decoder. The combined delay value is known as the coder's processing delay.
- ✓ The time to accumulate the block of samples is known as the algorithmic delay.

25. Define quantization error? [D]

The difference between the actual signal amplitude and the corresponding nominal amplitude is called as quantization error.

26. Define Quantization noise? [D]

The Quantization error values will vary randomly from sample to sample and hence quantization error is also known as quantization noise

27. Define companding? [D]

Companding refers to a technique for compressing and then expanding (or decompressing) an analog or digital signal.

28. What is the main difference in DPCM and DM? [D]

DM encodes the input sample by only one bit. It sends the information about + S or - S i.e. steprise or fall.

DPCM can have more than one bit for encoding the sample. It sends the information about difference between actual sample value and predicted sample value

29. Define granular noise. How it is reduced. [D]

When the original input signal has relatively constant amplitude, the reconstructed signal has variations that were not present in the original signal. This is called granular noise. Granular noise can be reduced by decreasing the step size

30. Define Dynamic range?[D]

The ratio of the peak amplitude of a signal to its minimum amplitude is known as the dynamic range of the signal.

**PART – B
FIRST HALF**

Sampling and Quantization of Speech (PCM) – Adaptive differential PCM

1. Explain in detail about sampling and quantization with neat block diagram. (13)[D]
2. Explain in detail about PCM encoder and decoder with neat block diagram. (13)[D]
3. Explain DPCM & Three order predictive DPCM with block diagram.(16) [D] [Apr/May-2017]
4. Discuss the technique of DPCM with neat diagrams. What are the advantages of ADPCM over DPCM? (8) [D] [Nov/Dec-2016]
5. Discuss the methodology of achieving higher levels of compression by making the predictor coefficients associated with the ADPCM adaptive. (8) [D] [Nov/Dec-2015]
6. Draw and explain the adaptive differential PCM encoder and decoder. (8) [D] [Nov/Dec-2014]
7. Discuss the technique of DPCM with neat diagrams. What are the advantages of ADPCM over DPCM? (8) [D] [Apr/May-2015]
8. Using a block representation explain DPCM compare it with PCM technique.(13) [Apr/May-2018]
9. Draw and explain the blocks in ADPCM encoder and decoder.(13)[Apr/May-2019]

Delta Modulation – Vector Quantization

1. Explain in detail about delta modulation with neat diagram. (13) [D]
2. Explain in detail about adaptive delta modulation with neat diagram. (13) [D]
3. Explain in detail about vector quantization.(13) [D]

SECOND HALF

Adaptive predictive coding & linear Predictive coding

1. Explain the operation of channel vocoders. (8) [D] [May/Jun-2016]

2. Linear predictive coding. (8) [D] [Nov/Dec-2017]
3. Explain Linear Predictive Coding and code excited LPC? (16) [D] [EC2037-Nov/Dec-2017]

Code excited LPC-perpetual coding

1. Explain the principle perceptual coders and also explain how they differ from LPC coders. (8) [D] [Nov/Dec-2015]
2. Perceptual coding. (8) [D] [Nov/Dec-2017]
3. The LPC - 10 speech coder's quality deteriorates rapidly with strong background noise. Discuss why MELP works better in the same noisy condition? (8) [D] [May/Jun-2016]
4. Give a brief note on linear predictive coding and code excited LPC. (8) [D] [Nov/Dec-2014]

UNIT II - IMAGE AND VIDEO COMPRESSION PART – A

1. What are the two basic types of images?

- ✓ Computer generated images (Graphics)
- ✓ Digitized images (Documents and pictures)

2. List out the types of computer generated images?

- ✓ GIF
- ✓ TIFF

3. List out the types of Digitized images?

- ✓ FAX
- ✓ Scanner
- ✓ MPEG files

4. Define global color table?

The table of colors relate to whole image is referred to as global color table.

5. Define local color table?

The table of colors relates to portion of image is referred to as global color table.

6. Explain over scanning technique.

Over scanning technique states that all line starts with a minimum of one white pixel.

7. Expand READ?

Relative Element Address Designate

8. List out the modes used in MMR coding?

- a. Pass Mode
- b. Vertical Mode
- c. Horizontal Mode

9. Define extension mode?

It is a unique codeword that aborts the coding operation prematurely before the end of the page.

10. Define Lossy Sequential Mode / Baseline Mode?

Lossy Sequential Mode / Baseline Mode is intended for the compression of both monochromatic and color digitized pictures/images as used in multimedia communication applications.

11. List out the five main stages associated with the baseline mode of operation?

- ✓ Image/block preparation,
- ✓ Forward DCT
- ✓ Quantization
- ✓ Entropy encoding
- ✓ Frame building

12. List out the steps used in entropy encoding?

The entropy encoding stage comprises four steps:

- ✓ Vectoring
- ✓ Differential encoding
- ✓ Run-length encoding
- ✓ Huffman encoding

13. Define Quantization?

The quantization process aims to reduce the size of the DC and AC coefficients so that less bandwidth is required for their transmission.

14. Draw the JPEG encoder block?

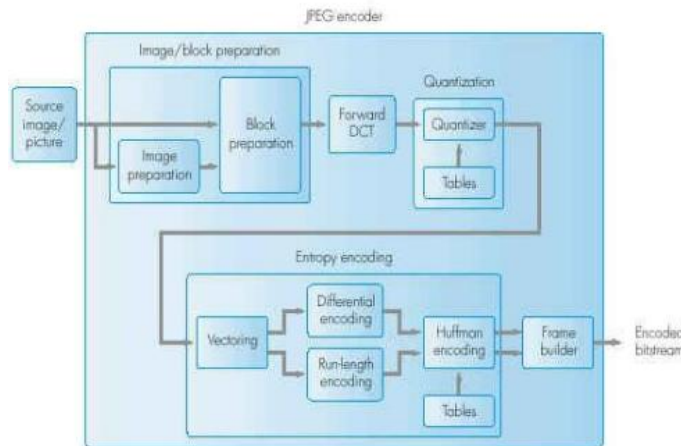

15. Draw the JPEG decoder block?

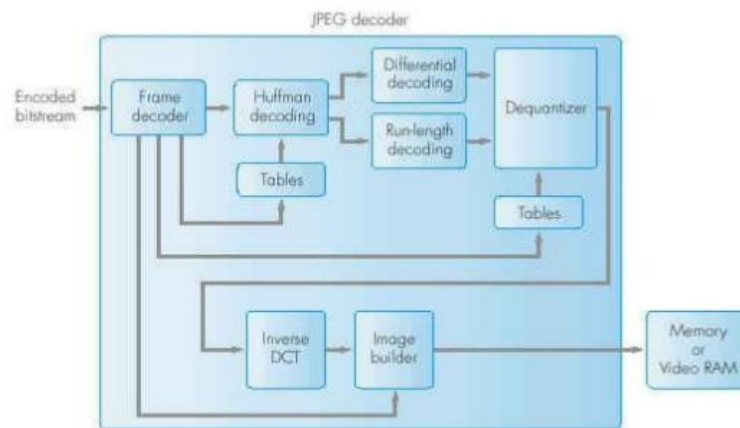

16. What is the functionality of loop filter in H.261? [D] [Apr/May-2019]

The loop filter is applied to the prediction data to reduce large errors when using interframe coding. Loop filtering provides a noticeable improvement in video quality but demands extra processing power.

17. How is reversible variable length code words created? [D] [Nov/Dec-2015]

A simple way for producing a set of RVLCs is to first choose a set of VLCs each of which has a constant hamming weight that is each codeword has the same number of binary 1s. The associated set of RVLCs is then produced by adding a fixed length prefix and suffix to each of the corresponding VLC's

VLC	RVLC
1	111
01	1011
001	10011
0001	100011

18. Write the applications suitable for H.261 standard. [D] [Nov/Dec-2014]

- ✓ Video telephony
- ✓ Teleconferencing over ISDN

19. Define GOP. Explain its working with an example. [D] [Nov/Dec-2017]

GOP is the abbreviation for Group of Pictures. It is the number of frames / pictures between two successive I frames.

20. Expand CIF & QCIF? [D]

- ✓ Common Intermediate Format
- ✓ Quarter Common Intermediate Format

21. What are the different frames in video compression? [D]

- ✓ I frame - Intracoded frame.
- ✓ P frame – Predictive frame
- ✓ B frame – Bidirectional frame
- ✓ PB frame – two neighboring P and B frames are encoded as a single frame.
- ✓ D frame – used for rewind and fast forward operations in video on demand applications

22. Define frame. [D]

An inter frame is a frame in a video compression stream which is expressed in terms of one or more neighboring frames.

23. Define MPEG. [D]

The Moving Picture Experts Group (MPEG) is defined as a sequence of digitized pictures.

24. What is the significance of H.261. [D]

H.261 is a video compression standard defined for using video telephony and video conferencing services over Integrated Services Digital Network (ISDN). This standard permits to use the bandwidth in multiples of 64 kbps. Only I and P frames are used.

25. Define Field Mode?

The motion vectors relate to the amount of movement that has taken place in the time to scan field

26. Define Frame Mode and Mixed Mode?

Frame Mode: The motion vectors relate to the amount of movement that has taken place in the time to scan two fields; that is, the time to scan a complete frame

Mixed mode: The motion vectors for both field and frame modes are computed and the one with the smallest (mean) values is selected

27. What are the schemes available in error resilience?

- ✓ Error tracking
- ✓ Independent segment decoding
- ✓ Reference picture selection

28. Expand BIFS?

BIFS stands for **B**inary **F**ormat **F**or **S**cenescenes

29. Define motion estimation?

The accuracy of the prediction operation is determined by how well any movement between successive frames is estimated. It is called as motion estimation.

30. Define motion compensation?

The estimation process is not exact, additional information must also be sent to indicate any small difference between the predicted and actual positions of the moving segments involved. This is known as motion compensation.

PART – B**Graphics Interchange format - Tagged image file format**

1. Write a brief note on image file formats. (6) [D] [Nov/Dec-2014]
2. Explain the GIF interlaced mode of compression. (8) [D] [May/Jun-2016]
3. Give a brief note on GIF and TIFF formats. (6) [D] [Apr/May-2015]

Digitized documents- Digitized pictures JPEG

1. With the help of a diagram identify the five main stages associated with the baseline mode of operation of JPEG and give a brief description of the role of each stage. (8) [D] [Nov/Dec-2015]
2. Explain the JPEG encoder and decoder with neat diagrams. (10) [D] [Nov/Dec-2014] [Apr/May-2015]
3. Identify the five main stages associated with the baseline mode of operation of JPEG and give a brief description of each stage. (8) [D] [May/Jun-2016]
4. Explain JPEG image compression technique. (16) [D] [EC2037-Nov/Dec-2017]
5. Draw and explain the baseline sequential JPEG encoding process.(13) [Apr/May-2019]

Video Encoding-Motion estimation

1. Explain the different types of frames in video compression principles. (16) [D] [Apr/May-2017]
2. With the aid of an example explain how DCT blocks are derived from macro blocks in an I frame. (8) [D] [Nov/Dec-2015]
3. Compare the principle and implementation of H.261 and H.263 video compression standards. (8) [D] [Nov/Dec-2014]
4. Explain the process of intra frame and inter frame predictive coding in H.261 algorithm. (8) [D] [May/Jun-2016]
5. A digitized video is to be compressed using the MPEG-1 standard assuming the frame sequence of IBBPBBPBBPBBI... And average compression ratios of 10:1(I), 20:1(P) and 50: 1(B). Derive the average compression ratio, average bit rate that is generated by the encoder for NTSC.(7) [Apr/May-2019]
6. Explain in detail about motion estimation. [D](13)
7. Give a brief note on H.261 video compression standard.[D](13)

Overview of H.263 and MPEG

1. Give a brief note on H.263 video compression standard. (6) [D] [Apr/May-2015]
2. Explain the working principles of H.263. (16) [D] [EC2037-Nov/Dec-2017]
3. Give a brief note on H.263 video compression standard. (6) [D] [Nov/Dec-2016]
4. Describe the principle of MPEG 4 with diagrams of encoder and decoder. (10) [D] [Nov/Dec-2016] [Nov/Dec-2015] [Nov/Dec-2014]
5. How is motion compensation performed in MPEG 4 coding? (8) [D] [May/Jun-2016]
6. Describe the principle of MPEG 4 with diagrams of encoder and decoder. (10) [D] [Apr/May-2015]
7. Explain Content based video coding principle. (16) [D] [Nov/Dec-2017]
8. With a neat diagram explain MPEG-4 and its Synchronization and delivery of streaming data.(13) [Apr/May-2018]
9. Discuss about error resilience techniques. (5) [Apr/May-2019]
10. Explain MPEG with a neat sketch. (8) [Apr/May-2019]

**UNIT III - TEXT COMPRESSION
PART – A**

1. How will you differentiate a typeface from a font? [Apr/May-2019]

A typeface is the collective name of a family of related fonts (such as Times New Roman), while fonts refer to the weights, widths, and styles that constitute a typeface (such as Times New Roman Regular, Italic, Bold, etc.)

2. Differentiate fixed length from variable length code. [Apr/May-2019]

- ✓ In a fixed-length code each codeword has the same length.
- ✓ In a variable-length code codewords may have different lengths.

	<i>a</i>	<i>b</i>	<i>c</i>	<i>d</i>	<i>e</i>	<i>f</i>
Freq in '000s	45	13	12	16	9	5
a fixed-length	000	001	010	011	100	101
a variable-length	0	101	100	111	1101	1100

3. Define Entropy encoding. [Apr/May-2018] [Apr/May-2017] [May/Jun-2016]

Entropy encoding is a lossless data compression scheme that is independent of the specific characteristics of the medium. It creates and assigns a unique prefix-free code to each unique symbol that occurs in the input.

4. Define differential encoding. [D] [Apr/May-2017]

Techniques that transmit information by encoding difference are called differential encoding. Differential encoding schemes are very popular for speech coding.

5. Bring out the differences between loseless and lossy compression. [D] [Nov/Dec-2016]

LOSSLESS COMPRESSION	LOSSY COMPRESSION
Lossless compression algorithm, when the compressed information is decompressed, there is no loss of information to be reversible	Lossy compression algorithms, is normally not to reproduce an exact copy of the source information after decompression
Transform coding, DCT, DWT, fractal compression, RSSMS.	RLW, LZW, Arithmetic encoding, Huffman encoding, Shannon Fano coding.
Images, audio and video.	Text or program, images and sound.

6. Define the term 'Run length coding'. [D] [Nov/Dec-2016]

Run-length Encoding or RLE is a technique used to reduce the size of a repeating string of characters. This repeating string is called a run; typically RLE encodes a run of symbols into two bytes, a count and a symbol. RLE can compress any type of data regardless of its information content, but the content of data to be compressed affects the compression ratio. Compression is normally measured with the compression ratio.

7. Create a dynamic Huffman tree for the text "This is Anna University".[Nov/Dec-2015]

8. Give the objectives of lossy compression algorithms. [D] [Nov/Dec-2014]

The main objective of lossy compression is to reduce the number of bits for representing number the source information by introducing acceptable loss of information. It has higher compression ratio.

9. State dynamic Huffman coding. (or) Write the principle of dynamic Huffman coding. (Or) What are the advantages of adaptive Huffman coding over Huffman coding? [D] [Apr/May-2018] [May/Jun-2016] [Nov/Dec-2014]

Adaptive Huffman coding (also called Dynamic Huffman coding) is an adaptive coding technique based on Huffman coding. It permits building the code as the symbols are being transmitted, having no initial knowledge of source distribution, that allows one-pass encoding and adaptation to changing conditions in data.

10. When does a codeword said to have prefix property? [D] [Apr/May-2015]

A code is said to have the prefix property if no codeword is a prefix of any other codeword.

11. Give the principle of differential encoding. [D] [Apr/May-2015]

Techniques that transmit information by encoding difference are called differential encoding. Differential encoding schemes are very popular for speech coding.

12. Define Run Length Encoding. [D] [Nov/Dec-2017]

Run length encoding is very simple form of data compression in which consecutive sequences of same data value are stored or transmitted as a single data value and count.

13. If there is a ZIP code file format means which kind of compression technique is used to unzip the data? [ID] [Nov/Dec-2017]

ZIP is an archive file format that supports lossless data compression

14. Define Lossless compression. [D] [EC2037-Nov/Dec-2017]

Lossless compression is a class of data compression algorithms that allows the original data to be perfectly reconstructed from the compressed data.

15. What is Huffman code tree? [D] [EC2037-Nov/Dec-2017]

Huffman coding operation involves creating an unbalanced tree with some branches shorter than the others. The resulting tree is called as Huffman code tree.

16. Define arithmetic coding. [D]

Arithmetic coding is a form of entropy encoding used in lossless data compression. When a string is converted to arithmetic encoding, frequently used characters will be stored with fewer bits and not-so-frequently occurring characters will be stored with more bits, resulting in fewer bits used in total. A code word defines an interval of number between 0 and 1

17. What is variable length coding? [D]

Variable Length Coding is the simplest approach to error free compression. It reduces only the coding redundancy. It assigns the shortest possible codeword to the most probable gray levels.

18. What are the different compression methods? [D]

The different compression methods are,

- i. Run Length Encoding (RLE)
- ii. Arithmetic coding
- iii. Huffman coding and
- iv. Transform coding

19. Use Huffman code to derive the minimum average number of bits per character needed to encode the given characters with their probability of occurrence: A and B = 0.25, C and D = 0.14, E, F, G and H = 0.055. [ID]

The minimum average number of bits is obtained by the entropy of the message and it is defined as

$$\text{Entropy (H)} = \sum_{i=1}^n P_i \log_2 \frac{1}{p_i}$$

$$\begin{aligned} H &= 2 \times \{ [0.25 \log_2(1/0.25)] + [2 \times \log_2(1/0.14)] + [4 \times 0.055 \log_2(1/0.055)] \} \\ &= 2 \times \{ [0.25 \log_2(4)] + [2 \times \log_2(7.14)] + [4 \times 0.055 \log_2(18.18)] \} \\ &= 2.475 \text{ bits/symbol} \end{aligned}$$

20. Give the general features of entropy coding. [D]

- ✓ Entropy encoding is lossless
- ✓ It is independent of type of information to be compressed. It concerns mainly how the information is represented.
- ✓ e.g. Run-length encoding and Statistical encoding

21. What is entropy of information? [D]

The minimum average number of bits that are required to represent a symbol in a message is known as entropy (H).

$$\text{Entropy (H)} = \sum_{i=1}^n P_i \log_2 \frac{1}{p_i}$$

22. State the basic principle of statistical coding. [D]

Statistical coding uses variable length code words for the symbols. Most frequently occurring symbols are assigned less number of bits (smallest code word)

23. Define the term compression ratio. [D]

The data compression ratio is the ratio of the size of the uncompressed data to the size of compressed data.

$$\text{Compression Ratio} = \text{size of uncompressed data} / \text{size of compressed data}$$

24. Give one application each suitable for lossy and lossless compression. [D]

Lossy compression is applied to compress an image or a video where as lossless compression is applied when a text document is to be compressed.

25. What do you mean by optimum prefix code? [D]

In a set of variable length code words, the shorter code word should not be the start of longer code words. This is called prefix property. The code will be optimum if more frequently occurring symbols are assigned shorter code words compared to less frequently occurring symbols.

26. Define Lempel-Ziv-Welch? [D]

A compression algorithm that codes strings of characters with codes of a fixed number of bits. Every new string in the input is added to a table until it is full. The codes of existing strings are output instead of the strings. It is also known as LZW compression.

27. List the type of Lempel-Ziv algorithm? [D]

- ✓ LZ77 algorithm
- ✓ LZ78 algorithm

28. Define Lempel-Ziv coding? [D]

The Lempel Ziv compression algorithm instead of using single characters as the basis of the coding operation uses strings of characters. It is also called as dictionary based compression algorithms.

29. Define leaf node? [D]

The termination point of a branch is known as a leaf node.

30. Define root node & branch node? [D]

The base of the tree is known as a root node and the point at which a branch divides is a branch node.

PART – B
FIRST HALF

Compression principles-source encoders and destination encoders-lossless and lossy compression entropy encoding –source encoding

1. Compare a one dimensional coding scheme with a two dimensional encoding scheme. (8) [ID] [Nov/Dec-2015]
2. Explain in detail about lossless and lossy compression. (16) [D] [Nov/Dec-2017]
3. Describe briefly about lossy and lossless compression.(4) [Apr/May-2019]
4. State the following: (13) [Apr/May-2018]
 - i) Source encoders and destination decoders(4)
 - ii) Lossless and Lossy compression techniques (4)
 - iii) Entropy Encoding(3)
 - iv) Source Encoding.(2)

Text compression

1. Design a Huffman code and find average length for a source that puts out Letters from an alphabet $A = \{a_1, a_2, a_3, a_4, a_5\}$ with $P(a_1) = P(a_3) = P(a_4) = 0.1$, $P(a_2) = 0.3$ and $P(a_5) = 0.4$. (8) [D] [Nov/Dec-2016]
2. A series of message is to be transferred between two computers. The message comprises of the characters A, B, C, D and E. The probabilities of occurrence of the above characters are 0.4, 0.19, 0.16, 0.15 and 0.1 respectively. Use Huffman coding to obtain a codeword for the above characters. Determine the average number of bits per codeword. (10) [D] [Apr/May-2015] (8) [D] [Nov/Dec-2014]

Static Huffman coding dynamic coding

1. Find Huffman codeword of the , given text "AAAAAAAAAABBBBBBCCCSS" by static Huffman tree. Calculate Entropy & Derive the average number of bits per character for codeword? (16) [D] [Apr/May-2017]
2. Describe dynamic Huffman code for the same output source with the above probabilities. (8) [D] [Nov/Dec-2016]
3. Consider the string ARBER, apply Huffman coding and decode it. (16) [D] [Nov/Dec-2017]
4. Find Huffman codeword of the given text "GOOD DAY" by constructing Dynamic Huffman tree? [D] (16)
5. Encode the following data using static Huffman coding and find the efficiency of the code with $m_1 = 0.4$, $m_2 = 0.15$, $m_3 = 0.15$, $m_4 = 0.15$, $m_5 = 0.15$.(9) [Apr/May-2019]

Arithmetic coding

1. Generate arithmetic code for the sequence 1233 with cdf $F_x(1) = 0.8$, $F_x(2) = 0.82$ and $F_x(3) = 1$. (8) [D] [Nov/Dec-2016]
2. The symbol probability table is given below. Write the code word for CAEE\$ using Arithmetic Encoding scheme. (8) [D] [May/Jun-2016]

Symbol	A	B	C	D	E	F	\$
Probability	0.2	0.1	0.2	0.05	0.3	0.05	0.1

3. Explain arithmetic coding with suitable example. (16) [EC2037-Nov/Dec-2017]
4. Write the following symbols and probabilities of occurrence; encode the Message "went" using arithmetic coding algorithms. [D] (16)

Symbols:	e	n	t	w	#
Prob :	0.3	0.3	0.2	0.1	0.1

Lempel ziv- Lempel ziv welsh

1. Explain Lempel Ziv Welsh Compression. (16) [D] [Apr/May-2017]
2. Explain in detail about LZW algorithm. (8) [D] [Nov/Dec-2016]
3. Discuss the principle of Lempel-Ziv and Lempel-Ziv-Welsh coding techniques. (8) [D] [Nov/Dec-2014]
4. Explain the principle of operation of LZ compression algorithm. Assume a dictionary of 16,000 words and an average word length of 5 bits; derive the average compression ratio that is achieved relative to using 7 bit ASCII code word. (8) [ID] [Nov/Dec-2015]
5. Let a simple dictionary contain the following string with their respective codes.

String	A	B	C
Code	1	2	3

Now if the input string is ABAABBABCABABBA, how does the LZW compression algorithm work? (8) [D] [May/Jun-2016]

6. Discuss the principle of Lempel Ziv-Welsh coding. (6) [D] [Apr/May-2015]
7. Explain Lempel Ziv Welsh Compression with necessary example and its disadvantages.(13) [Apr/May-2018]
8. Explain with an example arithmetic coding (or) Lempel-Ziv coding .(7) [D] [Apr/May-2019]
9. Use the LZW algorithm to compress the string: BABAABAAA The steps involved are systematically shown in the diagram below.
10. Explain in detail about LZ77 & LZ78 algorithms

UNIT IV - GUARANTEED SERVICE MODEL

PART – A

1. What is network dimensioning? [D]

How to design a network topology (where to place routers, how to interconnect routers with links, and what capacity to assign to links) to achieve a given level of end-to-end performance is a network design problem is called as network dimensioning.

2. Explain the scenario that creates packet jitter. [D]

Jitter in IP networks is the variation in the latency on a packet flow between two systems, when some packets take longer to travel from one system to the other. A jitter buffer can mitigate the effects of jitter, either in the network on a router or switch, or on a computer

3. What is Round Robin scheduling? [D]

Round-robin is one of the algorithms employed by process and network schedulers in computing. As the term is generally used, time slices are assigned to each process in equal portions and in circular order, handling all processes without priority.

4. Give the reservation styles in RSVP. [D]

RSVP reservation styles are:

- ✓ **Fixed filter** - reserves resources for a specific flow.
- ✓ **Shared explicit** - reserves resources for several flows and all share the resources.
- ✓ **Wildcard filter** - reserves resources for a general type of flow without specifying the flow; all flows share the resources.

5. What is meant by RSVP? [D]

RSVP (Resource Reservation Protocol) is a signaling protocol that is used to reserve resources like bandwidth and router buffers in internet to guarantee Quality of Services

6. What are the limitations of best effort service? [D]

The limitations of best-effort service are packet loss, excessive end-to-end delay and packet jitter.

7. What is meant by steaming? [D]

Streaming media is video or audio content sent in compressed form over the internet & played immediately. It avoids the process of saving the data to the hard. By streaming, a user need not wait to download a file to play it.

8. What is meant by streaming stored audio and video? [D]

Streaming live audio/video is similar to the broadcasting of audio and video by radio and TV stations. Instead of broadcasting to the air, the stations broadcast through the Internet. There are several similarities between streaming stored audio/video and streaming live audio/video. They are both sensitive to delay; neither can accept retransmission. However, there is a difference. In the first application, the communication is unicast and on-demand. In the second, the communication is multicast and live. Live streaming is better suited to the multicast services of IP and the use of protocols such as UDP and RTP. Examples: Internet Radio, Internet Television (ITV), Internet protocol television (IPTV)

9. Define the best effort service and give an example. [D]

The IP based Internet phone and Real-time video conferencing services are called the best effort services because these services do not make any promise for minimum end-to-end delay or minimum jitter or minimum lose of packets. Retransmission of lost packets is generally not acceptable for interactive real-time audio application. Internet takes its best effort to move each datagram from its source to destination.

10. Is there any advantage in combining RTP and RTSP protocol? Why? [D]

RTSP is an application-level protocol designed to work with lower-level protocols like RTP, RSVP to provide a complete streaming service over internet. It provides means for choosing delivery channels (such as UDP, multicast UDP and TCP), and delivery mechanisms based upon RTP.

11. Give the applications of real time streaming protocol. [D]

Real Time Streaming Protocol(RTSP) is used by the client application to communicate to the server information such as the requesting of media file, type of clients applications, mechanism of delivery of file & other actions like resume, pause, fast forward & rewind. It is mostly used in entertainment & communication system to control streaming media servers.

12. Define the term quality of service. [D]

In VoIP quality means, being able to listen and speak in a clear and continuous voice. This is affected by the packets lost and the delay (create jitter) occurring in receiving the packets.

13. Write about scheduling and policing mechanisms. [D]

- ✓ First-in-First-out, Priority queuing, Round Robin and Weighted Fair Queuing are the scheduling mechanisms.
- ✓ Leaky bucket mechanism along with Weighted Fair Queuing is used for policing.

14. Define FIFO. [D]

FIFO Stands for "First In, First Out." FIFO is a method of processing and retrieving data. In a FIFO system, the first packet entered are the first ones to be removed.

15. Define any four quality of service parameters related to multimedia transmission. [D]

- ✓ End-to-end delay
- ✓ Jitter
- ✓ Packet loss
- ✓ Throughput

16. What are the components of traffic conditioning functions in Differentiated Service? [D]

- ✓ Classifier
- ✓ Meter
- ✓ Marker
- ✓ Shaper
- ✓ Dropper

17. What are the techniques to improve QoS? [D]

- ✓ Scheduling,
- ✓ Traffic shaping,
- ✓ Admission control
- ✓ Resource reservation

18. What is meant by RED? [D]

Random early detection (RED), also known as random early discard or random early drop is a queuing discipline for a network scheduler suited for congestion avoidance. If buffers are constantly full, the network is congested. Tail drop distributes buffer space unfairly among traffic flows

19. Define data rate and latency as QoS parameters for multimedia data transmission. [D]

Data rate : The speed at which data is transferred within the computer or between a peripheral device and the computer, measured in bytes per second.

Latency : Time taken by a packet to reach the destination is called latency

20. Define Traffic Shaping? [D]

Traffic Shaping is a mechanism to control the amount and the rate of the traffic sent to the network. It helps to regulate rate of data transmission and reduces congestion.

21. List out the types of traffic shaping algorithms. [D]

- ✓ Leaky Bucket
- ✓ Token Bucket

22. Define Resource and Traffic Specification? [D]

Resource Specification (Rspec) : Rspec defines the QoS being requested. It defines the resources such as buffer and bandwidth that the flow needs to reserve

Traffic Specification (Tspec) : Tspec defines the traffic characterization of the flow

23. List out the primary messages used by RSVP? [D]

- ✓ Path message
- ✓ Resv message

24. What are the three approaches proposed for quality of service? [D]

- ✓ Integrated services (IntServ)
- ✓ Differentiated services (DiffServ)
- ✓ Laissez-faire approach

25. What is Laissez-faire approach? [D]

Laissez-faire approach cares about delays and quality of service, such that the network will never be congested.

26. Define Per Hop Behavior (PHB)? [D]

A Per Hop Behavior is a predefined rule that influences how the router buffers and link bandwidth are shared among competing behavior aggregates. It can be defined in terms of router resources(eg. buffer and bandwidth), in terms of priority relative to other PHBs or in terms of relative traffic properties(eg. delay and loss)

27. Define Resource reservation. [D]

The only way to guarantee that a call will have the resources (link bandwidth, buffers) needed to meet its desired Quality of Service is to explicitly allocate those resources to the call. This process known as resource reservation.

28. What is expedited forwarding? [D]

The expedited forwarding PHB specifies that the departure rate of a class of traffic from a router must equal or exceed a configured rate.

29. What is assured forwarding? [D]

The assured forwarding PHB divides incoming traffic into four classes, where each AF class is guaranteed to be provided with some minimum amount of bandwidth and buffering space.

30. What is WFQ? [D]

Weighted fair queuing (WFQ) is a method of automatically smoothing out the flow of data in packet-switched communication networks by sorting packets to minimize the average latency and prevent exaggerated discrepancies between the transmission efficiency afforded to narrowband versus broadband signals.

PART – B
FIRST HALF

[Best Effort service model – Scheduling and Dropping policies]

1. Describe the different scheduling mechanisms suitable for multimedia systems with suitable diagrams. (8)[D]
2. Explain the dropping policing mechanisms adopted in multimedia networks with necessary diagrams. (8) [D]
3. Describe the principle and applications of scheduling and dropping policing mechanisms for providing QoS guarantees. (13) [D]
4. Summarize the important points on: i) Leaky bucket (4) (ii) WFQ (4) [D]
5. Explain in detail about Best Effort service model?(8)[D]

[Network Performance Parameters – Quality of Service and metrics – WFQ and its variants]

1. Summarize how Network Performance measures the service quality of a network? (8)[D]
2. Explain in detail about WFQ and its variants. (13) [D]
3. Explain in detail about Quality of Service and metrics. (13) [D]

[Random Early Detection]

1. Explain in detail about random early detection. (13) [D]

[QoS aware Routing – Admission Control – Resource Reservation – RSVP]

1. Explain the principle and applications of RSVP. (13) [D]
2. Discuss in detail about QoS aware Routing. (13) [D]
3. Summarize the important points on Admission Control & Resource Reservation. (13) [D]

[Traffic Shaping Algorithms – Caching]

1. Discuss in detail about various Traffic Shaping Algorithms with neat diagram. (13) [D]
2. Write shot notes on caching.(8)[D]

[Laissez Faire Approach]

1. Give a detail notes on Laissez Faire Approach. (13) [D]

[Possible Architectures – An Overview of QoS Architectures]

1. Give a brief note on integrated and differential services. (13) [D]

UNIT V MULTIMEDIA COMMUNICATION

PART – A

1. **List out the classifications of temporal relationship? [D]**
 - ✓ Object stream interactions
 - ✓ Media Levity
 - ✓ Media synchronization
2. **Define Medium? [D]**
Medium means for distribution and presentation of information. Examples: Text, Graphics, Speech and Music
3. **List out the classification of media. [D]**
 - ✓ Perception
 - ✓ Representation
 - ✓ Presentation
 - ✓ Storage
 - ✓ Transmission
 - ✓ Information exchange
4. **Define data stream? [D]**
Uninterrupted flow of a long sequence of data, such as in audio and video data files.
5. **Define Asynchronous Transmission Mode? [D]**
Asynchronous transmission mode provides for communication with no timely restrictions. Packets reach the receiver as fast as possible. Protocols of the worldwide Internet for electronic mail transmission are an example.
6. **Define Synchronous Transmission Mode? [D]**
Synchronous transmission mode defines a maximum end-to-end delay for each Packet of a data stream. A packet can reach the receiver at any arbitrary earlier time.
7. **Define Isochronous Transmission Mode? [D]**
Isochronous transmission mode- defines, besides a maximum end-to-end delay for each packet of a data stream, a minimum end-to-end delay. This means that the delay of individual packets is bounded.
8. **Define The Perception Medium? [D]**
Perception media help humans to sense their environment.
9. **List the characteristics of continuous media streams? [D]**
 - ✓ According to the time intervals between consecutive packets.
 - ✓ According to the variation of the amount between consecutive packets.
 - ✓ According to the continuity or connection between consecutive packets.
10. **Define Object Stream Interactions? [D]**
 - ✓ **Intramedia:** Temporal relationship between the objects of one stream. Example: Animation without sound.
 - ✓ **Intermedia:** Temporal relationship between the objects of two parallel streams. Example: Video clip with sound.
 - ✓ **User Interaction:** The temporal constraints in terms of response time. Example: Edutainment system.
11. **Define Media Levity? [D]**
 - ✓ **Live:** Live presentation demanding minimum end-to-end delay. Example: Video conference.
 - ✓ **Stored :** Stored presentations retrieved from secondary storage. Example: Video-on-demand.
 - ✓ **Mixed :** Combination of live and stored presentations. Example: Collaborative conference.

12. Define types of Media Synchronization? [D]

- ✓ **Asynchronous**: No well-defined timing relationships between objects. Example: Text entry on a keyboard.
- ✓ **Synchronous**: Well-defined temporal relationship between the objects of different streams. Example: Video with sound.
- ✓ **Isochronous**: Well-defined time relationship between the objects of the same stream. Example: Sound.

13. Define Spatial and Temporal composition? [D]

- ✓ **Spatial composition** relates to the placement of multimedia objects in space at any point in time.
- ✓ **Temporal composition** takes care of synchronization between object streams

14. Define Point and Stream synchronization? [D]

- ✓ **Point synchronization** is used when a single object in one stream must be synchronized with an object in another stream at one point in time.
- ✓ **Stream synchronization** is done continuously over a period of time, as in the case of a video presentation. Stream synchronization is also called continuous synchronization

15. Define user interactivity? [D]

The interaction between the user and the system is termed user interactivity.

16. Define mixed presentation? [D]

A mixed presentation uses a combination of live and stored information. A collaborative conference is an example of a mixed presentation. One window on the computer screen shows live pictures, while other windows are used to show stored information and user interactions.

17. Define Spatial Transformations. [D]

Transformations that take place in space are called spatial transformations. These include transitions such as fading of images or audio, mixing of channels, color changes, etc

18. Define SIP. [D]

Session Initiation Protocol (SIP) is a signaling protocol used for initiating, maintaining, modifying and terminating real-time sessions that involve video, voice, messaging and other communications applications and services between two or more endpoints on IP networks

19. What is SIP message request? [D]

SIP requests are the codes used to establish a communication. To complement them, there are SIP responses that generally indicate whether a request succeeded or failed.

INVITE is used to initiate a session with a user agent.

BYE is the method used to terminate an established session.

REGISTER request performs the registration of a user agent.

CANCEL is used to terminate a session which is not established.

ACK is used to acknowledge the final responses to an INVITE method.

OPTIONS method is used to query a user agent or a proxy server about its capabilities and discover its current availability

20. Why is H. 323 protocols designed? [D]

The H.323 is a signaling protocol used in telephony networks. It is designed to communicate a desire to set up a call, establish the call and finally close the call. This is the first set of widely deployed VoIP signaling system

21. What is meant by steaming? [D]

The client typically begins video playout within a few seconds after it begins receiving the video from the server. This means that the client will be playing out from one location in the video while at the same time receiving later parts of the video from the server. This technique, known as streaming.

22. Define any four quality of service parameters related to multimedia data transmission. [ID]

- ✓ Data Rate
- ✓ Latency
- ✓ Packet loss
- ✓ Jitter
- ✓ Sync skew

23. Draw and give the interaction between client and server using RTSP? [D]

SETUP: The client asks the server to allocate resources for a stream and start an RTSP session.

PLAY: The client asks the server to start sending data on a stream allocated via SETUP.

PAUSE: The client temporarily halts the stream delivery without freeing server resources.

TEARDOWN: The client asks the server to stop delivery of the specified stream and free the resources associated with it.

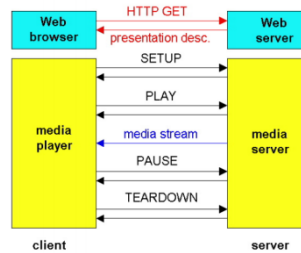

24. What is RTCP? [D]

RTCP (real time transport control protocol) synchronizes the two media streams prior to carrying out the decoding operation. It will allow performing system level function.

25. Draw the RTP header Format. [D]

Payload Type	Sequence Number	Timestamp	Synchronization Source identifier	Miscellaneous Fields
--------------	-----------------	-----------	-----------------------------------	----------------------

26. Define jitter. [D]

Jitter is defined as a variation in the delay of received packets. Due to network congestion, improper queuing, or configuration errors, this steady stream can become lumpy, or the delay between each packet can vary instead of remaining constant.

27. Define RTSP. [D]

The Real Time Streaming Protocol (RTSP) is a network control protocol designed for use in entertainment and communications systems to control streaming media servers. The protocol is used for establishing and controlling media sessions between end points

28. Name any two packet loss recovery schemes. [D]

- ✓ Forward-error Correction
- ✓ Interleaving

29. Define packet loss. [D]

Packet loss occurs when one or more packets of data travelling across a computer network fail to reach their destination. Packet loss is either caused by errors in data transmission, typically across wireless networks or network congestion

30. What is end to end delay? [D]

End-to-end delay or one-way delay (OWD) refers to the time taken for a packet to be transmitted across a network from source to destination.

PART – B
FIRST HALF

[Stream characteristics for Continuous media]

1. Explain in detail about various mediums used in multimedia. **(13)[D]**
2. Explain in detail about various Data Streams Characteristics. **(5)[D]**
3. Explain in detail about Data stream characteristics for continuous Media. **(13)[D]**

[Temporal Relationship – Object Stream Interactions, Media Levity, Media Synchronization]

1. Explain in detail about classifications of temporal relationships. **(13) [D]**

[Models for Temporal Specifications]

4. Explain the operation different models used to specify temporal relationships. **(13) [D]**

SECOND HALF

[Streaming of Audio and Video]

1. Give a detail notes on Multimedia protocols for real time interactive applications with an example. **(13)[D]**
2. Explain in detail about Streaming Stored Audio and Video with neat diagrams. **(13)[D]**

[Jitter – Fixed playout and Adaptive playout – Recovering from packet loss]

1. Explain about the delay that an internet phone needs to face. **(13)[D]**
2. Discuss about the Limitations of a Best-Effort Service. **(13)[D]**
3. Explain in detail about fixed playout and adaptive playout delay. **(13)[D]**
4. Explain about loss recovery schemes to preserve acceptable audio quality in the presence of packet loss. **(13)[D]**

[RTSP]

1. Explain the principle and working of Real Time Streaming Protocol. **(13)[D]**

[Multimedia Communication Standards – RTP/RTCP – SIP and H.263]

1. Explain the H.323 architecture and protocol in detail and write its applications. **(13)[D]**
2. Define and explain the architectures of SIP.(16) **(13)[D]**
3. Explain in detail about RTP. **(13)[D]**
4. Explain the information contained in RTCP packet types. **(13)[D]**
